

REDMOND

Multicooker
RMC-M95



User manual

Manufacturer: "Power Point Inc Limited" №1202 Hai Yun Ge (B1) Lin Hai Shan Zhuang Xiameilin Futian Shenzhen China. 518049. Under license of REDMOND®
Производитель: «Пауэр Пойнт Инк. Лимитед» №1202 Хай Юн Ге (B1) Лин Хай Шан Чжуан Сямейлин Футьян, Шеньжень, Китай, 518049. По лицензии REDMOND®
Виробник: «Пауер Пойнт Інк.Лімітед» № 1202 Хай Юн Ге (B1) Лін Хай Шан Чжуан Сямейлін Футьян, Шеньжень, Китай, 518049. За ліцензією REDMOND®

Importer (EU): SIA "SPILVA TRADING" Address: Jelgava, Meiju cels 43 – 62, LV-3007 Reg. Nr. 43603078598. **CY Importer** Cyprus: ASBIS Kypros Limited; 26, Spyrou Kyprianou Str, 4040, Germa-
sogeia, Limassol, Cyprus. Tel: +357 25 257 350; Fax: +357 25 322 432, e-mail: info@asbis.com.cy; www.asbis.com.cy

CONTENTS

IMPORTANT SAFEGUARDS	9	"МАКАРОНЫ" Program.....	13
Technical Specifications	10	"ХЛЕБ" Program.....	13
Programs	10	III. COOKING TIPS.....	13
Functions.....	10	Recommended Steaming Time Settings For Various Products	14
Packaging Arrangement.....	10	"МУЛЬТИПОВАР" Temperature Adjustment Recommendations	15
Multicooker Assembly.....	10	Table of default settings.....	15
Control Panel.....	10	IV. ADDITIONAL FEATURES	15
Display.....	10	V. OPTIONAL ACCESSORIES	16
I. PRIOR TO FIRST USE	10	VI. CLEANING AND MAINTENANCE	16
II. OPERATION	11	General rules and recommendations.....	16
Setting The Cooking Time.....	11	Cleaning the body.....	16
Time Delay Function.....	11	Cleaning the bowl	16
Keep Warm Function.....	11	Cleaning the inner lid.....	16
Disabling The Keep Warm In Advance	12	Cleaning the removable steam valve.....	16
Reheat Function.....	12	Condensate removal	16
Standard Operating Procedure for Automatic Programs.....	12	Cleaning the working chamber	16
"МУЛЬТИПОВАР" Program	12	Transportation and Storage	16
"МОЛОЧНАЯ КАША" Program.....	12	VII. BEFORE CALLING FOR SERVICE	17
"ТУШЕНИЕ" Program	13		

A1

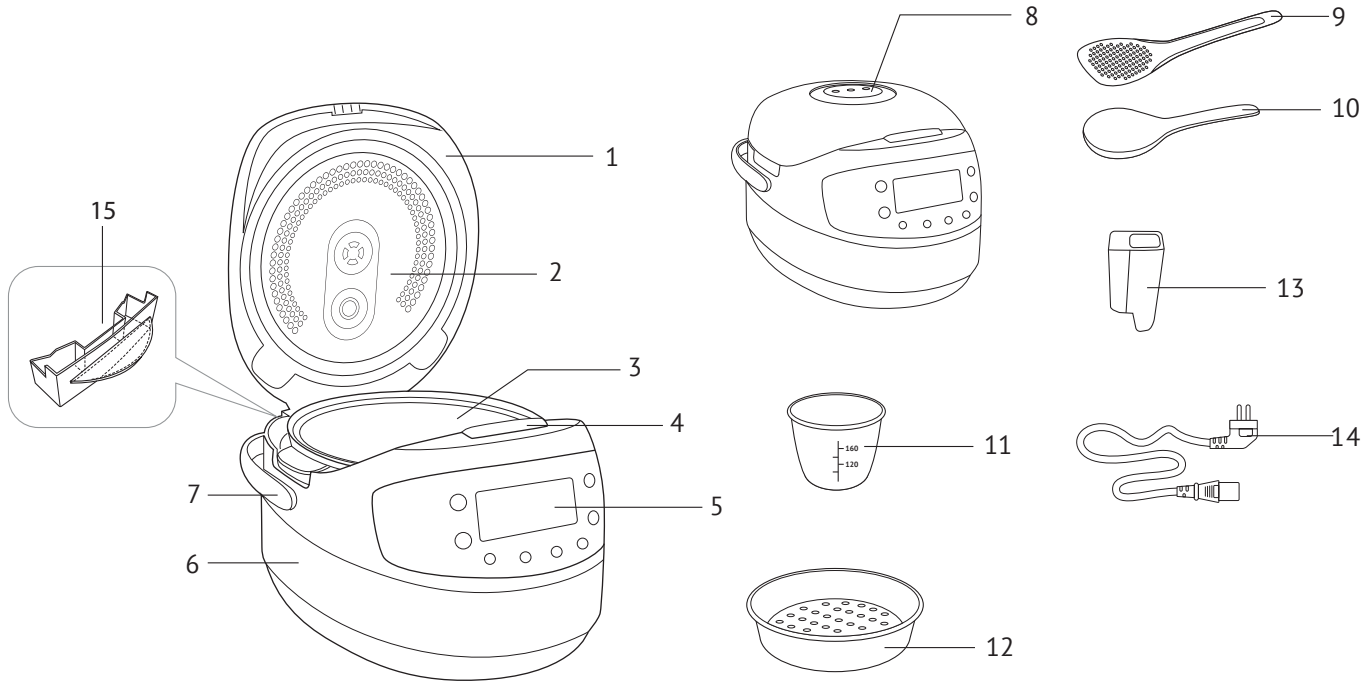

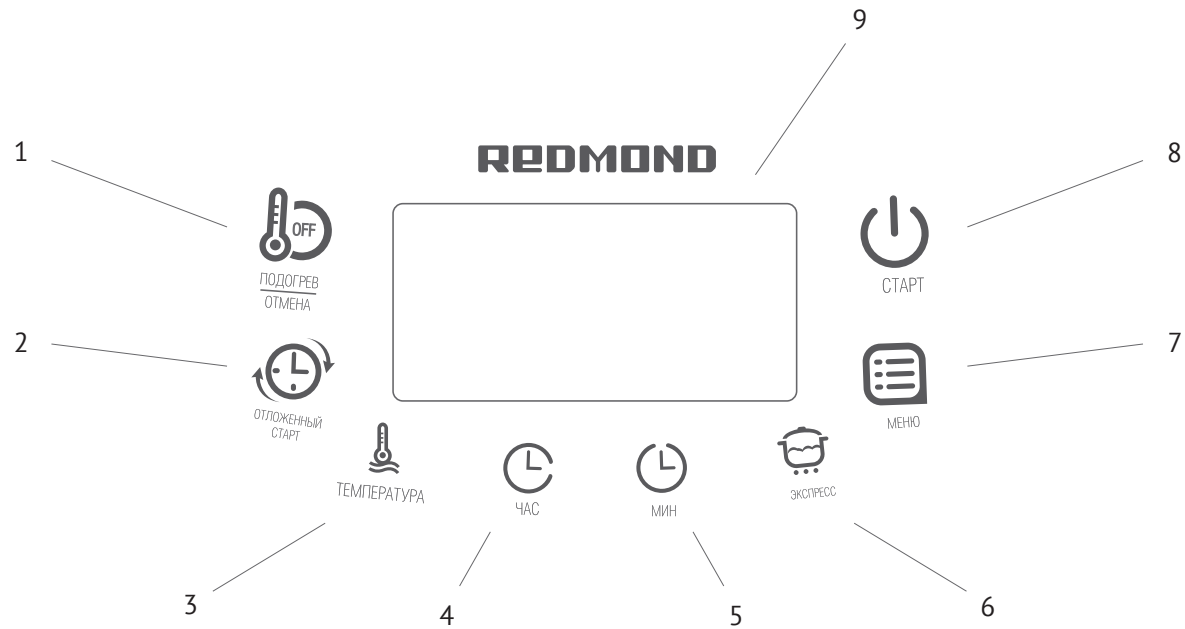

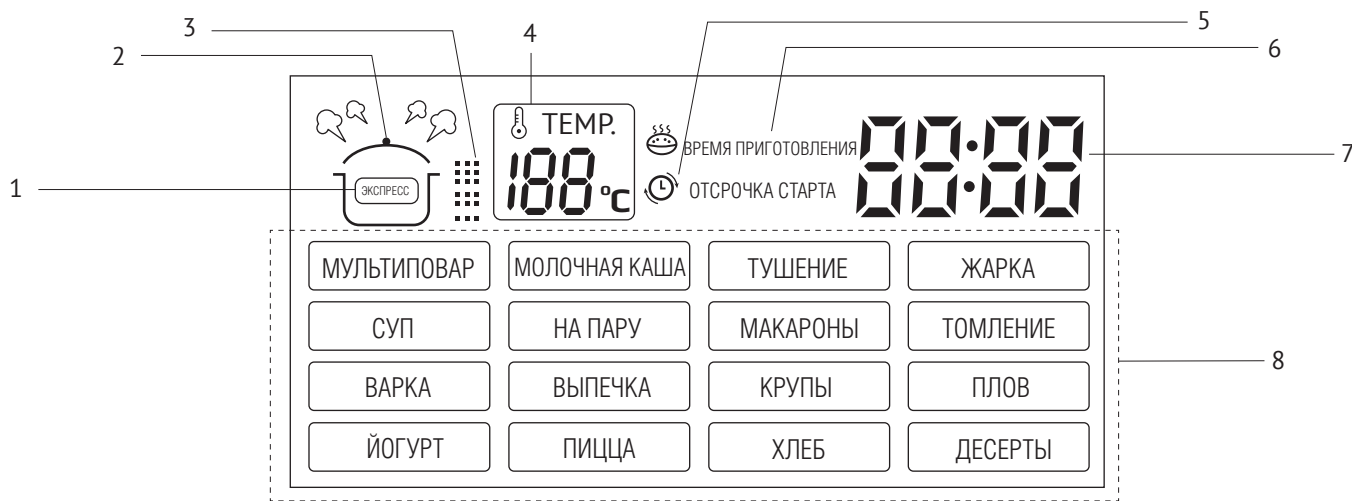

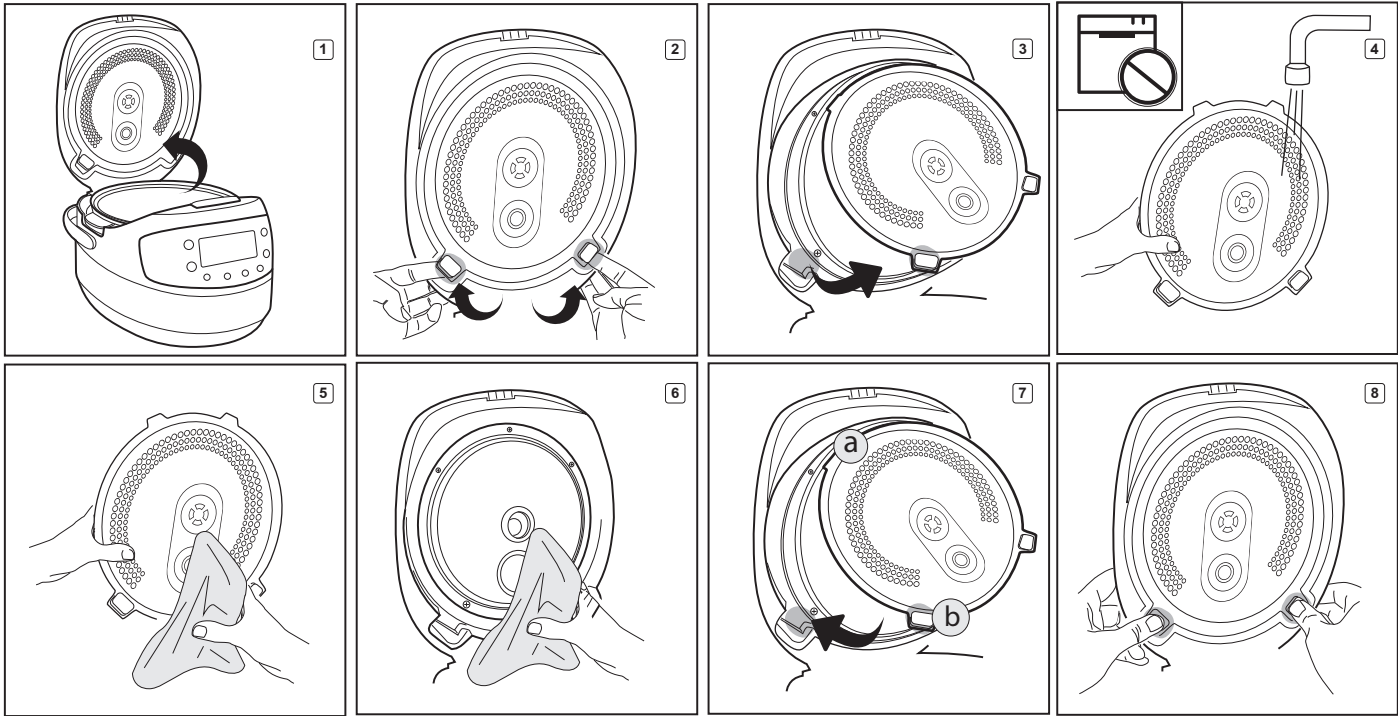

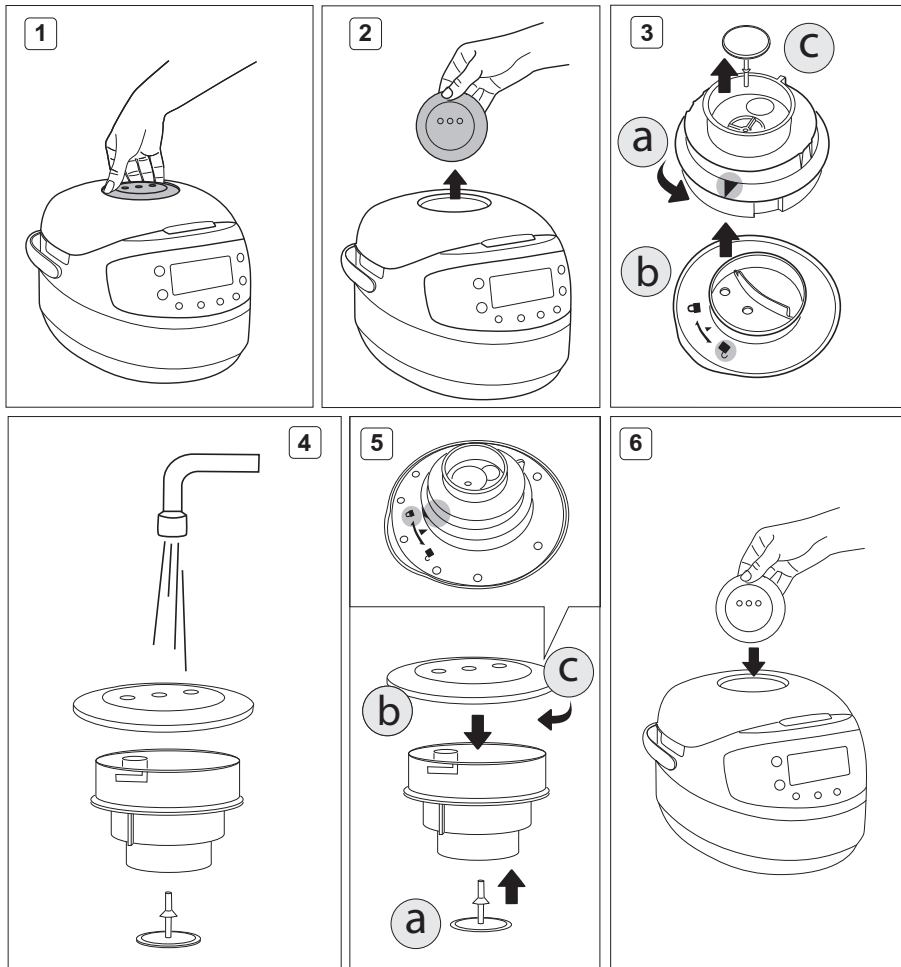

 Carefully read all instructions before operating and save them for future reference. By carefully following these instructions you can considerably prolong the service life of your appliance.

The safety measures and instructions contained in this manual do not cover all possible situations that may arise during the operation of the appliance. When operating the device the user should be guided by common sense, be cautious and attentive.

IMPORTANT SAFEGUARDS

- The manufacturer shall not be responsible for any failures arising from the use of this product in a manner inconsistent with the technical or safety standards.
 - This appliance is intended to be used for nonindustrial use in household and similar spheres of application. Industrial application or any other misuse will be regarded as violation of proper service conditions. Should this happen, manufacturer is not responsible for possible consequences.
 - Before plugging in the appliance ensure that the circuit voltage matches operating voltage of the appliance (see technical specifications or manufacturer's plate on the appliance).
 - Use an extension cord designed for power consumption of the appliance as the parameter mismatch may result in a short circuit or fire outbreak.
 - The appliance must be grounded. Connect the appliance only to a properly installed power point. Failure to do so may result in the risk of electrical shock. Use only grounded extension cords.
-  **CAUTION!** While in use the appliance heats up! Care should be taken to avoid touching the housing, bowl, or any other metal parts while operating. Make sure your hands are protected before handling the device. To avoid burns, do not lean over the appliance while opening the lid.
- Unplug the appliance after use, before cleaning or moving. Remove the power cord with dry hands holding it by the plug, not cord.
 - Do not place the cord in doorframes or by heat sources. Do not twist or bend the power cord, ensure it is not in contact with sharp objects, corners and edges of furniture.

 **PLEASE, NOTE:** damaging the cord may lead to a failure that will not be covered by the warranty. If the cable is damaged or requires replacing, contact an authorized service center to have the cord replaced.

- Never place the device on soft surfaces or cover it to keep ventilation slots clear of any obstruction.
- Do not operate the appliance outdoors to prevent water or any foreign object or insect from getting into the device. Doing so may result in serious damage of the appliance.
- Always unplug the device and let it cool down before cleaning. Follow cleaning and general maintenance guidelines when cleaning the unit.

 **DO NOT immerse the device in water or wash it in running water!**

- This appliance can be used by children over 8 y.o. and physically or mentally challenged persons or as well as those who lack experience and knowledge only provided they have been given supervision or instruction concerning use of the appliance in a safe way and understand the hazards involved. Children should not play with the appliance. Keep the appliance and the power cord out of reach of children under 8 y.o. Cleaning and maintenance should not be performed by children without supervision.
- Packaging material (film, foam, etc.) may be hazardous to children. Choking hazard! Keep the packaging out of the reach of children.
- Any kind of modification or adjustment to the product is not allowed. All the repairs should be carried out by an authorized service center. Failure to do so may result in the device breakage, property damage or physical injury.

 **CAUTION!** Do not use the appliance in case any defect has been noticed!

Technical Specifications

Model.....	RMC-M95
Power Input.....	860-1000 W
Supply Voltage.....	220-240 В, 50/60 Hz
Electrical safety.....	class I
Bowl capacity.....	5 L
Bowl coating.....	ceramic non-stick
Display.....	color, LED
3D heating.....	yes
Overall dimensions.....	377 × 285 × 240 mm
Net weight.....	3.4 kg

Programs

- | | |
|-----------------------------|---------------------------|
| 1. МУЛЬТИПОВАР (MULTI COOK) | 10. ВЫПЕЧКА (BAKE) |
| 2. МОЛОЧНАЯ КАША (OATMEAL) | 11. КРУПЫ (GRAIN) |
| 3. ТУШЕНИЕ (STEW) | 12. ПЛОВ (PILAF) |
| 4. ЖАРКА (FRY) | 13. ЙОГУРТ (YOGURT/DOUGH) |
| 5. СУП (SOUP) | 14. ПИЦЦА (PIZZA) |
| 6. НА ПАРУ (STEAM) | 15. ХЛЕБ (BREAD) |
| 7. МАКАРОНЫ (PASTA) | 16. ДЕСЕРТЫ (DESSERT) |
| 8. ТОМЛЕНИЕ (SLOW COOK) | 17. ЭКСПРЕСС (EXPRESS) |
| 9. ВАРКА (BOIL) | |

Functions

Keep Warm function.....	up to 24 hours
Disabling "Keep Warm" in advance.....	yes
Reheat function.....	up to 24 hours
Time Delay function.....	up to 24 hours

Packaging Arrangement

Multicooker.....	1 pc.
Bowl.....	1 pc.
Steaming container.....	1 pc.
Deep fry basket.....	1 pc.
Measuring cup.....	1 pc.
Serving spoon.....	1 pc.
Stirring paddle.....	1 pc.
Spoon/Paddle holder.....	1 pc.
Power cord.....	1 pc.
Cookbook.....	1 pc.
User manual.....	1 pc.
Service booklet.....	1 pc.

In accordance with the policy of continuous improvement, the manufacturer reserves the right to make any modifications to design, packaging arrangement, or technical specifications of the product without prior notice. The specification allows an error of ±10%.

Multicooker Assembly (A1, p. 4)

- | | |
|---------------------------------|---|
| 1. Upper lid | 9. Stirring paddle |
| 2. Removable inner lid | 10. Serving spoon |
| 3. The bowl | 11. Measuring cup |
| 4. Lid release button | 12. Steaming container |
| 5. Control panel with a display | 13. Spoon/Paddle holder |
| 6. The housing | 14. Power cord |
| 7. Carrying handle | 15. Container for collecting condensate |
| 8. Removable steam valve | |

Control Panel (A2, p. 5)

Multicooker REDMOND RMC-M95 is equipped with a touch control panel with color LED multifunction display.

- "Подогрев/Отмена" (Reheat/Cancel) button disables/reactivates the Reheat function, interrupts the program and cancels all settings.
- "Отложенный старт" (Time Delay) button is used to enter the time setting mode in Time Delay function.
- "Температура" (Temperature) button is used to adjust the temperature in MULTI COOK.
- "Час" (Hour) button is used to adjust the hours in time setting Time Delay modes.
- "Мин" (Min) button is used to adjust the minutes in time setting Time Delay modes.
- "Экспресс" (Express) button starts "ЭКСПРЕСС" program.
- "Меню" (Menu) button is used to select an automatic cooking program and to disable the Keep Warm function in advance.
- "Старт" (Start) button starts the cooking program.
- Display.

Display (A3, p. 6)

- | | |
|--|-------------------------------------|
| 1. "ЭКСПРЕСС" program indicator | 5. Time Delay indicator |
| 2. Operating program / reheat function indicator | 6. Indicator of the timer operation |
| 3. Cooking stage indicator | 7. Timer |
| 4. "МУЛЬТИПОВАР" temperature indicator | 8. Selected program indicator |

I. PRIOR TO FIRST USE

Carefully remove the multicooker and its accessories from the packaging. Dispose of all packaging materials.

⚠ *Keep all warning labels, including the serial number identification label located on the housing. After transportation or storage at low temperatures allow the appliance to stay at room temperature for at least 2 hours before using.*

Wipe the housing of the appliance with a soft, damp cloth. Rinse the inner bowl with warm soapy water and dry thoroughly. An odour on first use of the appliance is normal and does not indicate a malfunction. In such case, clean the appliance, following "Cleaning and Maintenance". Place the appliance on a hard, even, horizontal surface so that the steam from the valve will not come into contact with wallpaper, decorative coverings, electronic devices or other items or materials which could be damaged by high humidity or temperatures.

Before use, make sure there are no chips or other defects on the outside or visible inside parts of the multicooker. There should be nothing caught between the bowl and the heating element.

⚠ **ATTENTION!** *It is forbidden to lift the device with the filled bowl by the handle.*

Do not switch on the device without the bowl installed or with empty bowl inside. In case of accidental start of a cooking program, it may result in critical overheating or damage of the anti-stick coating. Before frying, pour inside a little vegetable or sunflower oil

STOP **ATTENTION!** *It is forbidden to lift the device by the handles of the bowl!*

II. OPERATION

Setting The Cooking Time

Multicooker REDMOND RMC-M95 allows manually adjusting the cooking time, set by default for each program (except "ЭКСПРЕСС"). Time adjustment range and interval depend on the program of cooking selected. To set:

1. Select the cooking program. Press "Час" button repeatedly to adjust the hours. Hold the button down to scroll through the digits.
2. Press "Мин" button repeatedly to adjust the minutes. Hold the button down to scroll through the digits.
3. To set the cooking time of less than 1 hour press "Час" button repeatedly to reset to zero. Adjust the minutes using "Мин" button.
4. When the time is set (display keeps blinking) proceed to the next stage in accordance with the program selected. To cancel all settings, press "Подогрев/Отмена" button and reset.

STOP **IMPORTANT!** *Manually adjusting the cooking time, consider time adjustment range and interval of selected program, given in the table of default settings.*

i *For your convenience the cooking time range in all programs starts with the minimum setting, enabling you to prolong the operating time of the program, if the dish is undercooked.*

In certain automatic programs countdown starts only when the device reaches its operating temperature. E.g. If you set "НА ПАРУ" program on 5 minutes, the countdown of the program begins only when the water comes to a full boil providing enough steam.

Cooking time of the "МАКАРОНЫ" programme covers the period of time needed to bring water to a boil and to cook the ingredients. The device produces an audible sound upon boiling alarming you to put ingredients inside the bowl. Repress the "Старт" button to begin the countdown.

Time Delay Function

This function allows setting the program to finish by certain time. Cooking time may be delayed for a period from 10 minutes to 24 hours with 10 minute intervals. Setting Time Delay function, take the cooking time of the program into consideration. The time of a delay should be longer than the cooking time of the program selected; otherwise the program starts running right after you press "Старт".

When the automatic program is selected and the temperature and cooking time are adjusted, you may set the Time Delay.

1. Press "Отложенный старт" button to enter the Time Delay setting mode. The words Time Delay are displayed. Timer is blinking.
2. Press "Час" button repeatedly to adjust the hours in 24 hour format. Hold the button down to scroll through the digits.
3. Press "Мин" button repeatedly to adjust the minutes. Hold the button down to scroll through the digits.
4. If you need to set the delay of less than 1 hour, repeatedly press "Час" button to reset to zero and adjust the minutes using "Мин" button.
5. To cancel the settings press "Подогрев/Отмена" button and reset.
6. When the time is set press and hold down the "Старт" button. Time Delay function indicator lights up. Set program starts running and the countdown begins.
7. Your meal will be ready when the time set expires. When the program finishes, the device automatically switches to Keep Warm ("Подогрев/Отмена" button indicator lights up).
8. Press "Подогрев/Отмена" button to cancel the Keep Warm. Button indicator goes off.

i *Time Delay function is available in all automatic programs except "ЖАРКА", "МАКАРОНЫ" and "ЭКСПРЕСС".*

It is not recommended to use Time Delay function if dairy and other perishable products are being used (eggs, fresh milk, meat, cheese etc.).

Setting the Time Delay in "НА ПАРУ" program remember that the countdown starts only when the device reaches its operating temperature (water comes to a full boil).

Keep Warm Function

Function is being automatically activated at the end of the cooking program. When the program finishes, the temperature of the meal (70–75°C) is being maintained for a period of time up to 24 hours.

"Подогрев/Отмена" button indicator lights up and the Keep Warm count up is being displayed. Press and hold down "Подогрев/Отмена" button to disable the function.

Disabling The Keep Warm In Advance

Automatic activation of the Keep Warm function at the end of the program may sometimes be undesirable. REDMOND RMC-M95 allows disabling the function in advance, while setting the program or during its operation. Press and hold down the "Меню" button to cancel the function. "Подогрев/Отмена" button indicator goes off. To reactivate the function, repress and hold down the "Меню" button ("Подогрев/Отмена" button indicator goes off).

Reheat Function

REDMOND RMC-M95 can be used for warming up cold meals. To reheat:

- Put the products into the bowl. Place the bowl inside the device.
- Close the lid until it clicks into place and plug in the unit.
- Press and hold down "Подогрев/Отмена" button for a few seconds until an audible sound is produced. Corresponding indicators light up and reheating process begins. The timer starts its countdown.

The meal will be warmed up to 70–75°C and the temperature will be maintained for the next 24 hours. To cancel the function press and hold down "Подогрев/Отмена" button. Corresponding indicators go off.

i *The function may operate for a period of 24 hours, however, we recommend using it moderately, because a prolonged thermal exposure may sometimes affect flavor characteristics of the meal.*

Standard Operating Procedure for Automatic Programs

⚠ *IMPORTANT! When using the water boiling device (for example, when boiling products), DO NOT set the cooking temperature above 100°C. It may result in overheating and failure of the device. For the same reason, DO NOT use the "ХЛЕБ", "ЖАРКА" and "ВЫПЕЧКА" programs to boil water.*

1. Measure the ingredients according to the recipe.
2. Put them into the bowl. Make sure that all the ingredients including liquid are below the scale mark indicating maximum capacity. Place the bowl inside the device. The bowl and the heating element must fit tightly.
3. Close the lid until it clicks into place. Plug in the unit.

i *ATTENTION! If you cook at high temperatures with much vegetable oil, always leave the device lid open.*

4. Repeatedly press "Меню" button to select the program (corresponding indicator lights up).
5. Use Hour and "Мин" buttons to adjust the time set by default for each program.
6. Set Time Delay function if needed. Time Delay function is not available in "ЖАРКА", "МАКАРОНЫ" and "ЭКСПРЕСС" programs.
7. Press and hold down "Старт" button. Start and "Подогрев/Отмена" button indicators light up. Set program starts running and the countdown begins. Countdown of the "НА ПАРУ" program begins only when water comes to a full boil, providing enough steam. In "МАКАРОНЫ" – after water comes to a full boil, products are added and "Старт" button is being repressed.

8. Press and hold down "Меню" button to disable the Keep Warm function in advance if needed ("Подогрев/Отмена" button indicator goes off). Repress "Меню" button to reactivate the function. Keep Warm function is not available in "ЙОГУРТ" and "ХЛЕБ" programs.
9. When cooking time expires, the device makes an audible sound. Depending on your settings the unit either switches to Keep Warm ("Подогрев/Отмена" button indicator lights up) or enters standby mode ("Старт" button indicator blinks).
10. To interrupt cooking process at any stage, to cancel set program or the Keep Warm function press and hold down "Подогрев/Отмена" button.

📖 *For high-quality results, you are offered to use the recipes for cooking from the cook book supplied with REDMOND multicooker RMC-M95, designed specifically for this model.*

If the expected result has not been achieved, refer to the Cooking Tips section, where you can find answers to the most frequently asked questions and get the necessary recommendations.

If you did not achieve the desired result using automatic programs, try versatile program called "МУЛЬТИПОВАР", featuring a wide time and temperature adjustment range. This program gives endless opportunities for new culinary experiments.

"МУЛЬТИПОВАР" Program

This program can be used to cook any meal with your personal time and temperature settings. REDMOND RMC-M95, featuring "МУЛЬТИПОВАР" program will be able to replace a big number of kitchen appliances. Now any recipe, either from your family cookbook or Internet, can be adjusted for your multicooker.

For your convenience, the device does not switch to Keep Warm automatically by the end of the program if the cooking temperature was less than 80°C. It may be manually reactivated by pressing and holding down the "Меню" button right after the program starts running. "Подогрев/Отмена" button indicator lights up.

Temperature adjustment range (use "Температура" button to adjust) is from 35°C to 170°C with 5°C intervals.

Cooking time adjustment range is from 5 minutes to 12 hours with the following intervals: less than 1 hour – 1 minute, over an hour – 5 minutes.

STOP *If you use the "МУЛЬТИПОВАР" program for boiling the water (for example, when cooking products), it is FORBIDDEN to set the cooking temperature above 100°C.*

"МОЛОЧНАЯ КАША" Program

This program is recommended for cooking various porridges using milk. Program's default time is 10 minutes. Manual time adjustment is available. Time adjustment range is from 5 minutes to 1.5 hours with 1 minute intervals.

"МОЛОЧНАЯ КАША" program is recommended for cooking various oat porridges using pasteurized low fat milk. To avoid boiling away, we recommend you do the following:

- rinse grain thoroughly before cooking;
- grease the sides of the bowl with butter;

- follow proportions suggested in the recipe book. Increase or reduce amount of ingredients proportionally;
- using whole milk dilute it by half with water.

Cooking results may vary depending on the place of origin and the manufacturer of the products used.



If you did not manage to achieve the desired result, please consult the chapter "Cooking Tips" to receive necessary recommendations on cooking or use the multifunctional program "МУЛЬТИПОВАР". Set the temperature of 95°C. Follow the proportions and cooking time settings given in the recipe.

"ТУШЕНИЕ" Program

This program is recommended for steaming meat, fish, vegetable and children meals. Program's default time is 15 minutes. Manual time adjustment is available. Cooking time adjustment range is from 5 minutes to 2 hours with 5 minute intervals. Use the steaming container provided to steam the foods.

1. Pour 600–1000 ml of water into the bowl. Place the steaming container in.
2. Place the ingredients and put them into the container. Place the bowl inside the device. The bowl and the heating element must fit tightly.
3. Follow steps 3 to 10 given in "Standard operating procedure for automatic programs".



Countdown of the program does not start until the device reaches its operating temperature (water comes to a full boil).



If you want to adjust the default settings of the program we advise consulting the table of recommended steaming time settings for various products.

"МАКАРОНЫ" Program

This program is recommended for cooking pasta, sausages, eggs, etc. Program's default time is 8 minutes. Manual time adjustment is available. Cooking time adjustment range is from 2 to 20 minutes with 1 minute intervals. Cooking time of the program covers the period of time needed to bring water to a boil and to cook the ingredients. The device produces an audible sound upon boiling alarming you to put ingredients inside the bowl. Press the "Срап" button to begin the countdown. Time Delay function is not available in this program.



During preparation of certain products (pasta, etc.), foam might arise. To avoid foam boiling over, we recommend you to open the lid a few minutes after the products have been added into boiling water.

"ХЛЕБ" Program

This program is recommended for baking white and wheat-rye breads. The program includes complete baking cycle starting from the process of proofing the dough and up until the moment you take the freshly baked product out. Default time is 3 hours.

- Cooking time adjustment range is from 1 to 6 hours with 10 minute intervals. Keep Warm function is not available in this program.
- Adding ingredients into the bowl make sure that it is filled only to half of its size.

- Remember, that the baking starts one hour after the beginning of the program when the dough has proofed.



Before using baking flour, we advise you sift it, removing any impurities and adding to it some air.

It is not recommended to use Time Delay function because this may affect the quality of pastry.

Do not open the lid until the program finishes!

In order to minimize the cooking time and to simplify the process of baking we advise using baking flour mixes.

III. COOKING TIPS

This chapter familiarizes you with the practical tips and solutions to some common problems you may experience when using the multicooker.

THE DISH IS UNDERCOOKED

Possible Causes		Solving the Problem
The lid of the device was either open or was not closed properly.		Try to avoid opening the lid while cooking. Close the lid until it clicks into place. Make sure that the rubber sealing ring located on the inner side of the lid is not deformed or damaged in any way
Cooking temperature was not observed because the bowl and the heating element did not fit tightly.		There should not be any foreign objects between the lid and the housing of the device, remove if any. Always make sure that the heating element is clean and fits tightly with the bowl before cooking.
Wrong ingredients or settings were chosen. General proportions were not observed, the size of the ingredients was too large. Wrong time settings. Chosen recipe is not appropriate for the device.		We recommend using recipes adjusted for the device. Choose proven recipes only. Set the time and cooking program, choose ingredients, proportions, and the size of ingredients according to the recipe.
Steaming: the amount of water in the bowl is too little to provide enough steam.		Use the amount of water recommended. If in doubt, check the water level while steaming.
Frying:	Too much oil was added.	Frying ingredients add an amount of oil enough just to cover the bottom of the bowl. Follow recommendations given in the recipe while deep frying.
	Too much moisture inside the bowl.	Do not close the lid of the device while frying unless specified in the recipe. Using frozen ingredients defrost and drain before frying.
Cooking: the water boiled away during preparation of foods with high acidity.		Certain products need to be processed before cooking: washed, browned, etc. Follow recommendations given in the recipe.
Baking (dough did not bake through):	Too much dough in the bowl.	Use a smaller amount of dough.
	Proofed dough has reached the inner lid and covered the steam valve.	Take the baked product out of the unit, turn it over and place back. Bake until ready. Next time use smaller amount of dough.

THE DISH IS OVERCOOKED

Wrong ingredients, wrong size of ingredients or time settings.	We recommend using the recipes adjusted for your model. Try choosing proven recipes only.
The dish remained in the unit with the Keep Warm on for too long after it's been cooked.	Set the time and cooking program, choose ingredients, proportions, and the size of ingredients according to the recipe.
	We recommend using the "Keep Warm" function moderately. If your device features the function of disabling the "Keep Warm" in advance, use it to avoid the problem.

LIQUID BOILS AWAY DURING COOKING

Milk boils away.	Depending on the quality of milk used, it may boil away. To avoid this, we recommend using only ultra-pasteurized milk with the fat content of 2.5% or less. Dilute milk with water if needed (p. 7)
Ingredients were not properly processed (washed poorly, etc.). Wrong general proportions or ingredients.	We recommend using the recipes adjusted for the device. Try choosing proven recipes only. Set the time and cooking program, choose ingredients, proportions, and the size of ingredients according to the recipe. Whole grains, meat, fish, and seafood need to be rinsed thoroughly before cooking.
The product forms a foam	It is recommended to rinse the product thoroughly, remove the valve or cook with the lid open

THE DISH IS BURNT

The bowl was not properly washed after last use. Non-stick coating is damaged.	Make sure that the bowl is clean and has no coating defects before cooking.
General amount of ingredients is smaller than recommended.	Use proven recipes, adjusted for the device.
Cooking time was too long.	Reduce the cooking time or follow recommendations given in the recipe adjusted for your model.
Frying: oil was not added; the ingredients have not been stirred or turned over.	Frying products add amount of oil enough just to cover the bottom of the bowl. Stir ingredients thoroughly while frying or turn over as required.
Stewing: not enough liquid.	Add more liquid. Avoid opening the lid while stewing.
Cooking: not enough liquid (proportions were not observed).	Follow recommended ratio of liquids to solids while cooking.
Baking: the bowl was not greased before baking.	Grease the bottom and sides of the bowl with butter or oil before baking (do not pour oil inside).

INGREDIENTS LOOSE THEIR SHAPE WHEN COOKED

Ingredients have been over stirred.	Frying foods, do not stir the ingredients more often than every 5-7 minutes.
Cooking time was too long.	Reduce cooking time or follow recommendations given in the recipe adjusted for the device.

BAKED GOODS ARE OVERLY MOIST

Improper ingredients causing excess moisture have been used (juicy fruits or vegetables, frozen berries, sour cream, etc.).	Use ingredients according to the recipe. Try to avoid using ingredients causing excess moisture or use them in smaller amounts.
Baked product has been left in the unit with the closed lid for too long.	We recommend taking baked product out of the unit right after the baking cycle finishes or leaving it on the "Keep Warm" for a short period of time only.

BAKED GOODS DO NOT RISE

Eggs and sugar were poorly whipped.	Use proven recipes adjusted for the device. Choosing, measuring, and processing ingredients follow recommendations given in the recipe.
The dough stayed for too long before being baked.	
The flour wasn't sifted or the dough was poorly kneaded.	
Wrong ingredients.	

i Certain REDMOND multicookers feature an overheat protection in "ТУШЕНИЕ" and "СУП" programs. In case there is no liquid in the bowl, the device automatically interrupts the program and switches to Keep Warm.

Recommended Steaming Time Settings For Various Products

Product	Weight, g/pcs	Water, ml	Cooking time, min
Pork/beef fillet (cut into 1.5 cm cubes)	500	500	20/30
Mutton fillet (cut into 1.5 cm cubes)	500	500	25
Chicken fillet (cut into 1.5 cm cubes)	500	500	15
Meatballs/cutlets	180 (6 pcs) / 450 (3 pcs)	500	10/15
Fish fillet	500	500	10
Shrimps (cooked, peeled, frozen)	500	500	5
Potatoes (cut into 1.5 cm cubes)	500	500	15
Carrots (cut into 1.5 cm cubes)	500	500	35
Beet (cut into 1.5 cm cubes)	500	500	95
Frozen vegetables	500	500	10
Egg	3 pcs	500	10

i Remember, that these are general recommendations only. In reality, cooking time may vary from the recommended one, depending on the quality of the product used and on your personal preferences.

“МУЛЬТИПОВАР” Temperature Adjustment Recommendations

Temperature, °C	Recommendations for use (you may also refer to the recipe book)	Temperature, °C	Recommendations for use (you may also refer to the recipe book)
35	Proofing dough and making vinegar	105	Cooking jellied meat
40	Making yogurts	110	Sterilization
45	Leavening	115	Making sugar syrup
50	Fermentation	120	Making brisket
55	Fondant	125	Stewing meat
60	Making green tea and preparing baby food	130	Making puddings
65	Cooking vacuum sealed meat	135	Browning cooked foods
70	Preparing punch	140	Smoking various foods
75	Pasteurizing liquids and making white tea	145	Baking fish and vegetables in foil
80	Preparing mulled wine	150	Baking meat in foil
85	Making cottage cheese and other time consuming meals	155	Frying yeast dough
90	Making red tea	160	Frying poultry
95	Cooking porridges using milk	165	Frying steaks
100	Cooking meringues and jams	170	Deep frying French fries and chicken nuggets

Table of default settings

Program	Recommendations for use	Cooking time, set by default	Time adjustment range/setting interval	Time Delay	Preheating stage	Keep Warm
МУЛЬТИ-ПОВАР	Cooking various meals with your personal time and temperature settings	15 min	5 min – 1 hour / 1 min 1 hour – 12 hours / 5 min	✓		✓
МОЛОЧНАЯ КАША	Cooking porridges using milk	10 min	5 min – 1.5 hour / 1 min	✓		✓
ТУШЕНИЕ	Stewing meat, fish, vegetables, etc.	1 hour	20 min – 12 hours / 5 min	✓		✓
ЖАРКА	Frying meat, fish, vegetables, etc.	15 min	5 min – 1.5 hour / 1 min			✓

Program	Recommendations for use	Cooking time, set by default	Time adjustment range/setting interval	Time Delay	Preheating stage	Keep Warm
СУП	Making various soups and broths	1 hour	20 min – 8 hours / 5 min	✓		✓
НА ПАРУ	Steaming meat, fish, vegetables, etc.	15 min	5 min – 2 hours / 5 min	✓	✓	✓
МАКАРОНЫ	Cooking pasta, sausages and other semi-finished products	8 min	2 min – 20 min / 1 min		✓	✓
ТОМЛЕНИЕ	Making stewed meat, baked milk, brisket, jellied meat and aspic	5 hours	1 hour – 8 hours / 10 min	✓		✓
ВАРКА	Cooking beans and vegetables	40 min	5 min – 2 hours / 5 min	✓		✓
ВЫПЕЧКА	Baking cakes, puddings, pies, puff and yeast pastry	1 hour	20 min – 8 hours / 5 min	✓		✓
КРУПЫ	Cooking grains and other side dishes	35 min	5 min – 4 hours / 5 min	✓		✓
ПЛОВ	Making meat, fish, poultry and seafood pilafs	1 hour	20 min – 1.5 hours / 10 min	✓		✓
ЙОГУРТ	Making different kinds of yogurt; proofing dough	8 hours	6 hours – 12 hours / 10 min	✓		
ПИЦЦА	Making pizza	25 min	20 min – 1 hour / 5 min	✓		✓
ХЛЕБ	Baking white and wheat-rye breads including the proofing cycle	3 hours	1 hour – 6 hours / 10 min	✓		
ДЕСЕРТЫ	Making desserts using fresh fruits and berries	1 hour	5 min – 4 hours / 5 min	✓		✓
ЭКСПРЕСС	Quick cooking rice and other grains					✓

IV. ADDITIONAL FEATURES



- Proofing the Dough
- Making Fondue
- Making Cheese, Cottage Cheese
- Deep frying
- Pasteurizing Liquids
- Reheating Baby Food
- Tableware and Personal Items Sterilization

V. OPTIONAL ACCESSORIES

Additional accessories can be purchased separately. Information on the assortment, pricing, and compatible accessories is available through our authorized dealer in your country.

VI. CLEANING AND MAINTENANCE

General rules and recommendations

- Before using the device for the first time, as well as to remove the smell of food in the multicooker after cooking, you are recommended to process half a lemon in it for 15 minutes in the "HA ПАРУ" program.
 - If you do not use the device for a long time, unplug it. The working chamber, including the heating disc, bowl, inner lid, condensate container and steam valve must be clean and dry.
 - Before cleaning the device, make sure it is unplugged and completely cold. For cleaning, use a soft cloth and delicate dishwashing detergent.
-  *Do NOT use coarse wipes or sponges or abrasive pastes when cleaning the device. It is also unacceptable to use any chemically aggressive or other substances that are not recommended for use for objects in contact with food.*
-  *Do NOT immerse the device in water or place it under a stream of water!*
- Be careful when cleaning the rubber (silicone) parts of the multicooker: their damage or deformation may cause the device to malfunction.
 - The device body can be cleaned as it becomes dirty. The bowl, inner lid, condensate container and removable steam valve must be cleaned after each use. The condensate formed in the process of cooking in the device, remove after each use of the device. Clean the inner surfaces of the working chamber as necessary.

Cleaning the body

Clean the device body with a soft, damp kitchen cloth or sponge. It is possible to use a delicate cleaning agent. To avoid possible stains from water and stains on the body, you are recommended that you wipe the surface dry.

Cleaning the bowl

The bowl can be cleaned both manually using a soft sponge and dishwashing detergent, and in the dishwasher (in accordance with the recommendations of its manufacturer).

If it is heavily dirty, pour warm water into the bowl and leave to soak for a while, and then clean. Be sure to wipe the outer surface of the bowl dry before installing it in the body of the device.

With regular operation of the bowl, the color of its internal non-stick coating can completely or partially change. This is not a sign of a bowl defect.

Cleaning the inner lid

Refer to the diagram  (page 7) for the procedure for removing and installing the inner lid. Use a damp kitchen cloth or sponge to clean the main and removable inner lids. Before installing the inner lid, wipe the surfaces of both lids dry.

Cleaning the removable steam valve

The steam valve is installed in a special seat on the top lid of the device. Refer to the diagram  (page 8) for the cleaning procedure.

 *ATTENTION! To avoid deformation of the valve rubber seal, do not twist or pull it out when removing, cleaning and installing.*

Condensate removal

In this model, the condensate accumulates in a special cavity on the body of the device around the bowl and flows into a special container located at the back of the device. To clean the container, rinse it under running water, following the above rules. Remove any remaining condensation in the cavity around the bowl with a kitchen cloth.

Cleaning the working chamber

In strict compliance with the instructions of this manual, the probability of liquid, food particles or debris entering the working chamber of the device is minimal.

If significant contamination has occurred, the surfaces of the working chamber should be cleaned to avoid incorrect operation or damage to the device.

 *Before cleaning the working chamber of the device, make sure that the device is unplugged and completely cooled down!*

The side walls of the working chamber, the surface of the heating disc and the housing of the central temperature sensor (located in the middle of the heating disc) can be cleaned with moistened (not wet!) sponge or cloth. If you use detergent, you should carefully remove the residue to avoid the appearance of unwanted odor during subsequent cooking.

If foreign objects get into the recess around the central temperature sensor, carefully remove them with tweezers, without pressing on the sensor housing.

If the surface of the heating disc is dirty, it is allowed to use a moistened medium-hardness sponge or a synthetic brush.

 *With regular use of the device over time, the color of the heating disc can completely or partially change. This is not a sign of malfunction and does not affect the correct operation of the device.*

Transportation and Storage

Before repeated operation or storage completely dry all parts of the appliance. Store the assembled appliance in a dry, ventilated place away from heating appliances and direct sunlight.

During transportation and storage, do not expose the device to mechanical stress, that may lead to damage of the device and/or violation of the package integrity.

Keep the device package away from water and other liquids.

VII. BEFORE CALLING FOR SERVICE

Problem	Possible cause	Solving the problem	
Display shows the error code: E1–E4	System error; system board or heating element malfunction.	Unplug the unit and let it cool down. Close the lid tightly. Switch the unit back on. If this does not eliminate the error, address an authorized service center	
The device does not switch on.	Power cord is not connected to the appliance and/or socket	Ensure that the power cord is connected to the corresponding inlet on the housing of the appliance and to the socket	
	Wall socket is not working properly	Connect to a properly working wall socket	
	Power supply failure	Check the power supply. If not available, contact local electricity supply company	
Dish is taking too long to cook	Power supply interruption (power supply is unstable/underrated)	Ensure that the power supply is stable. If unstable/underrated, contact local electricity supply company	
Dish is taking too long to cook	There is a foreign object between the bowl and the heating element (grain, food particles, debris, etc.)	Unplug the appliance and let cool down. Remove foreign object or objects	
	The bowl is not properly positioned	Properly position the bowl into place	
	Heating disk is dirty	Unplug the appliance and let cool down. Clean heating disk	
Hot steam escapes from under lid during cooking. The count of program running time starts	Inner lid and cooking bowl fail to seal hermetically	The bowl is not properly positioned	Properly position the bowl into place
		The lid is not closed properly; foreign object under lid	Remove foreign objects (grain, food particles, debris, etc.) from under the rim, if any. Always close the lid until it clicks into place
		Sealing ring is dirty, deformed, or damaged in any way	Check the sealing ring. Replace, if necessary

i In case you didn't manage to eliminate the defects, please, refer to the authorized service centre.



Environmentally friendly disposal (WEEE)

The packaging, user manual and the device itself shall be taken to the applicable collection point for the recycling of electrical and electronic equipment. Do not throw away the electronic waste to help protect the environment.

Old appliances must not be disposed with other household waste but must be collected separately. Municipal disposal of recyclable wastes is free of charge. The owners of old appliances are required to bring it to a waste facility centre. With this little extra effort, you can help to ensure that valuable raw materials are recycled and pollutants are treated as appropriate.

This appliance is labelled in accordance with European Directive 2012/19/EU – concerning used electrical and electronic appliances (waste electrical and electronic equipment WEEE).

The guideline determines the framework for the return and recycling of used appliances as applicable throughout the EU.





www.redmond.company
www.multivarka.pro
www.store.redmond.company
www.smartredmond.com
Made in China

RMC-M95-ENG-UM-1